

Fiber-Fiber™ Large Core Fiber Optical Switch

(up to 1 mm diameter, ultra-broadband, 1x1, 1x2, bidirectional)



(Protected by U.S. patent 6823102 and pending patents)

DATASHEET

BUY NOW



Applications

- Protection
- Instrumentation

Features

- Low Optical Distortions
- 8 Ports Integration
- High Isolation
- High Reliability
- Fail-Safe Latching
- Epoxy-Free Optical Path
- Low Cost

The FFLS Series Fiber optical switch features fast rise/fall <5ms for large core fiber up to 1mm in diameter. It directly couples a pair of fibers and is activated via an electrical relay. The advanced design offers unmatched performances of ultra-broadband covering from 300 to 2400nm limited only by fiber intrinsic transmission, low optical loss, little wavelength dependence without coatings, high power handling, as well as low cost. The switch is bidirectional and conveniently controllable by 5V TTL. The latching operation preserves the selected optical path after the drive pulse has been removed, reducing power consumption. The switch has integrated electrical position sensors for verification.

Using no lens, the Fiber-Fiber Series switch accommodates fibers of multimode, double cladding, and large core. Index-matching liquid can be filled to further reduce the loss <0.2dB.

Lightpath in the device is bidirectional.

Specifications

Parameter	Min	Typical	Max	Unit
Operating Wavelength	300		5000	nm
Insertion Loss ^[1]		0.5	1.0 (1.2 ^[3])	dB
Polarization Depended Loss			0.1	dB
Wavelength Dependent Loss		0.05	0.3	dB
Cross Talk ^[1]	35	45	50	dB
Return Loss ^[1]	35			dB
Rise/Fall Time		3	8	ms
Repetition Rate			5	Hz
Repeatability			± 0.05	dB
Durability	10 ⁸			Cycles
Optical Power Handling	1	2	5 ^[4]	W
Switching Type	Latching / Non-Latching			
Operating Temperature	-5		+60	°C
Storage Temperature	-40		+60	°C
Fiber Type	100, 200, 300, 400, 500, 600 Core, or equivalent			µm

Notes:

[1]. Excluding Connectors. Measure @ Light source CPR<14 dB.

Legal notices: All product information is believed to be accurate and is subject to change without notice. Information contained herein shall legally bind Agiltron only if it is specifically incorporated into the terms and conditions of a sales agreement. Some specific combinations of options may not be available. The user assumes all risks and liability whatsoever in connection with the use of a product or its application.

Rev 05/10/24

© Photonwares Corporation

P +1 781-935-1200

E sales@photonwares.com

W www.agiltron.com

Information contained herein is deemed to be reliable and accurate as of the issue date. Photonwares reserves the right to change the design or specifications at any time without notice. Agiltron is a registered trademark of Photonwares Corporation in the U.S. and other countries.

Fiber-Fiber™ Large Core Fiber Optical Switch

(up to 1 mm diameter, ultra-broadband, 1x1, 1x2, bidirectional)



(Protected by U.S. patent 6823102 and pending patents)

DATASHEET

Mechanical Dimensions (mm)

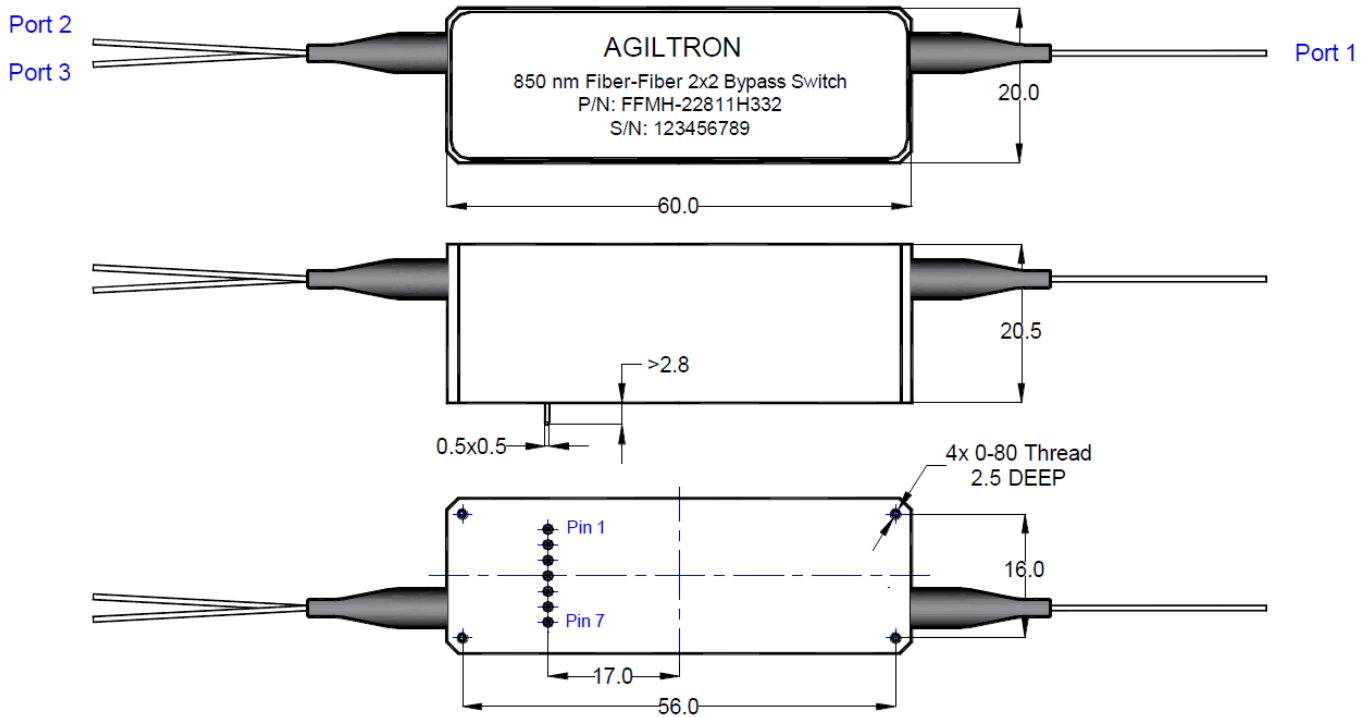

*Product dimensions may change without notice. This is sometimes required for non-standard specifications.

Fiber-Fiber™ Large Core Fiber Optical Switch

(up to 1 mm diameter, ultra-broadband, 1x1, 1x2, bidirectional)



(Protected by U.S. patent 6823102 and pending patents)

DATASHEET

Electrical Connector Configurations

The load is a resistive coil which is activated by applying 5V (draw ~ 40mA). Agiltron offers a computer control kit with TTL and USB interfaces and Windows™ GUI. We also offer RS232 interface as an option – please contact Agiltron sales.

Latching Type – Single Coil

Application Note: Applying a constant driving voltage increases stability. The switches can also be driven by a pulse mode using Agiltron recommended circuit for energy saving.

Status	OpticalPath			Electric Drive			Status Sensor	
	1x1	Dual 1x1	1x2	Pin 1	Pin 2	Pin 3	Pin 4 - 5	Pin 6 - 7
Status I	Port 1 → 1'	Port 1 → 1' Port 2 → 2'	Port 1 → 1'	0	5V Pulse	NC	Open	Open
Status II	Dark	Dark	Port 1 → 2'	0	NC	5V Pulse	Close	Close

- [1]. Typical Pulse width is 50 ms.
- [2]. We can provide 3V or other Driving voltage switches, please call sales.
- [3]. NC: No electric Connection.

Non-Latching Type

Status	OpticalPath					Electric Drive			Status Sensor	
	1x1 Transparent	1x1 Dark	Dual 1x1 Transparent	Dual 1x1 Dark	1x2	Pin 1	Pin 2	Pin 3	Pin 4 - 5	Pin 6 - 7
Status I	Port 1 → 1'	Dark	Port 1 → 1' Port 2 → 2'	Dark	Port 1 → 1'	0	NC	NC	Open	Open
Status II	Dark	Port 1 → 1'	Dark	Port 1 → 1' Port 2 → 2'	Port 1 → 2'	0	5V	NC	Close	Close

- [1]. We can provide 3V or other Driving voltage switches, please call sales.
- [2]. NC: No electric Connection.

Functional Diagram

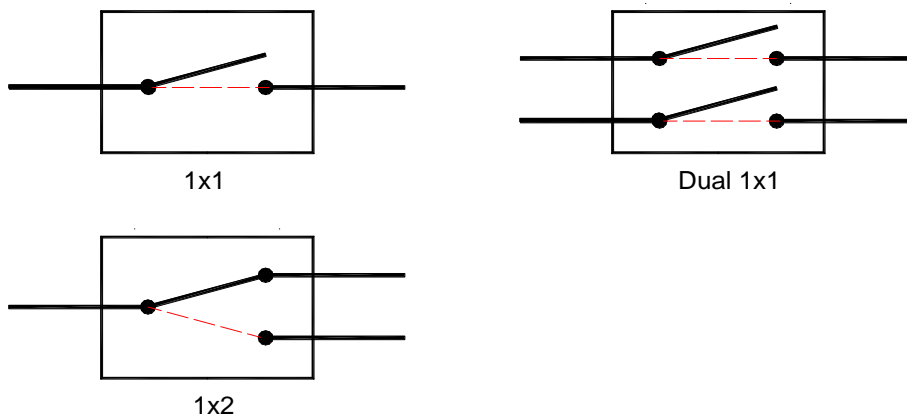

Fiber-Fiber™ Large Core Fiber Optical Switch

(up to 1 mm diameter, ultra-broadband, 1x1, 1x2, bidirectional)



(Protected by U.S. patent 6823102 and pending patents)

DATASHEET

Ordering Information

Prefix	Configuration	Test Wavelength [1]	Type	Package	Fiber Core Size	Fiber Cover	Fiber Length	Connector
FFLS-	1x1 = 11 1x2 = 12 Dual 1x1 = 33 Special = 00	488 = 4 630 = 6 780 = 7 850 = 8 980 = 9 1060 = 1 1310 = 3 1550 = 5 2000 = 2 Special = 0	Latching = 1 Non-latching = 2 Special = 0	Standard = 1 Special = 0	100 μm (NA0.22) = E 200 μm (NA0.22) = F 300 μm (NA0.22) = G 400 μm (NA0.22) = H 500 μm (NA0.22) = I 600 μm (NA0.22) = J Special = 0	Bare fiber = 1 2 mm Jacket = 2 900um tube = 3 Special = 0	0.25m = 1 0.5m = 2 1.0m = 3 Special = 0	None = 1 FC/PC = 2 FC/APC = 3 SC/PC = 4 SC/APC = 5 ST/PC = 6 SMA = S LC/APC = A LC/UPC = U Special = 0

[1]. The device is intrinsically ultra-broadband limited by the fiber's transmission. We only test at one selected wavelength to save cost. If a customer needs to test at several wavelengths, the selection is special =0 with added cost.

Fiber Core Alignment

Note that the minimum attenuation for these devices depends on excellent core-to-core alignment when the connectors are mated. This is crucial for shorter wavelengths with smaller fiber core diameters that can increase the loss of many decibels above the specification if they are not perfectly aligned. Different vendors' connectors may not mate well with each other, especially for angled APC.

Fiber Cleanliness

Fibers with smaller core diameters (<5 μm) must be kept extremely clean, contamination at fiber-fiber interfaces, combined with the high optical power density, can lead to significant optical damage. This type of damage usually requires re-polishing or replacement of the connector.

Maximum Optical Input Power

Due to their small fiber core diameters for short wavelength and high photon energies, the damage thresholds for device is substantially reduced than the common 1550nm fiber. To avoid damage to the exposed fiber end faces and internal components, the optical input power should never exceed 20 mW for wavelengths shorter 650nm. We produce a special version to increase the how handling by expanding the core side at the fiber ends.

Fiber-Fiber™ Large Core Fiber Optical Switch

(up to 1 mm diameter, ultra-broadband, 1x1, 1x2, bidirectional)



(Protected by U.S. patent 6823102 and pending patents)

DATASHEET

Typical Fiber Transmissions

